

- Single Device: 5A Output
- Input Voltage Range: 18V to 36V
- Adjustable Output Voltage
- Efficiencies up to 90%
- Remote Sense Capability
- Standby Function
- Excalibur™ Package

The PT6880 series is a new addition to Power Trends' line of 24V bus Integrated Switching Regulators (ISRs).

Designed for general purpose industrial applications, the PT6880 can operate up to 36V input at 5A of output current. The PT6880 is packaged in an 18-Pin version of Power Trends' distinctive Excalibur package, which is available in either the vertical or horizontal configurations, including surface-mount.

Please note that this product does not include short circuit protection.

Standard Application

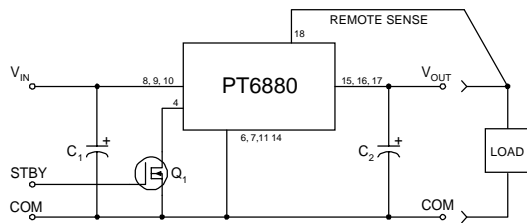

C₁ = Required 560µF electrolytic (1)
C₂ = Required 330µF electrolytic
Q₁ = NPN or Open Collector Gate

Ordering Information

- PT6881□ = +3.3 Volts
- PT6882□ = +2.5 Volts
- PT6883□ = +5.0 Volts
- PT6884□ = +9.0 Volts
- PT6885□ = +15.0 Volts
- PT6886□ = +12.0 Volts

(For dimensions and PC board layout, see Package Styles 1500 and 1510.)

PT Series Suffix

(PT1234X)

Case/Pin Configuration

Vertical Through-Hole	N
Horizontal Through-Hole	A
Horizontal Surface Mount	C

Specifications

Characteristics (T _a = 25°C unless noted)	Symbols	Conditions	PT6880 SERIES			Units	
			Min	Typ	Max		
Output Current	I _o	T _a = 60°C, 200 LFM, pkg P T _a = 25°C, natural convection	0.1 (2) 0.1 (2)	— —	5.0 5.0	A A	
Input Voltage Range	V _{in}	0.1A ≤ I _o ≤ I _{o max}	+18V	—	+36V	V	
Output Voltage Tolerance	ΔV _o	Over V _{in} range T _a = -40°C to +65°C	V _o -0.1	—	V _o +0.1	V	
Output Voltage Adjust Range	V _{oadj}	Pin 1 to V _o or ground	V _o = +3.3V V _o = +2.5V V _o = +5.0V V _o = +9.0V V _o = +12V V _o = +15V	2.2 1.8 3.0 6.0 9.0 10.0	— — — — — —	4.7 4.3 6.5 10.2 13.6 17.0	V
Line Regulation	Reg _{line}	+18V ≤ V _{in} ≤ +36V, I _o = I _{o max}	—	±0.5	±1.0	%V _o	
Load Regulation	Reg _{load}	V _{in} = +28V, 0.1 ≤ I _o ≤ I _{o max}	—	±0.5	±1.0	%V _o	
V _o Ripple/Noise mV _{pp}	V _n	V _{in} = +28V, I _o = I _{o max} V _o ≤ +6V V _o > +6V	—	50 1.0	—	%V _o	
Transient Response with C ₂ = 330µF	t _{tr} V _{os}	I _o step between 2.5A and 5.0A V _o over/undershoot	—	100 100	—	µSec mV	
Efficiency	η	V _{in} = +28V, I _o = I _{o max} V _o = +3.3V V _o = +2.5V V _o = +5.0V V _o = +9.0V V _o = +12.0V V _o = +15.0V	—	78 73 82 87 88 90	— — — — — —	% % % % % %	
Switching Frequency	f _o	+18V ≤ V _{in} ≤ +36V Over I _o range	500	550	600	kHz	
Maximum Operating Temperature Range	T _a	Over V _{in} range	-40	—	+85 (2)	°C	
Storage Temperature	T _s	—	-40	—	+125	°C	
Mechanical Shock	—	Per Mil-STD-883D, Method 2002.3	—	500	—	G's	
Mechanical Vibration	—	Per Mil-STD-883D, Method 2007.2, 20-2000 Hz, soldered in a PC board	—	15	—	G's	
Weight	—	—	—	23	—	gms	

Notes (1) The 560µF electrolytic input capacitor must be rated for 1.5Arms ripple current. Both input and output capacitors are required for proper operation.
(2) ISR will operate down to no load with reduced specifications.
(3) Consult the SOA curves or contact the factory to determine the appropriate derating.

Pin-Out Information

Pin	Function
1	V _{out} Adjust
2	Do Not Connect
3	Do Not Connect
4	STBY*- Standby
5	Do Not Connect
6	GND
7	GND
8	V _{in}
9	V _{in}
10	V _{in}
11	GND
12	GND
13	GND
14	GND
15	V _{out}
16	V _{out}
17	V _{out}
18	Remote Sense

PT6681, $V_{out} = 3.3V$ (Note A)

Efficiency vs Output Current

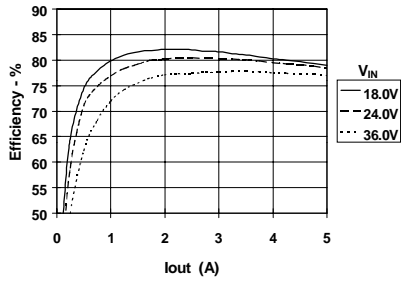

Ripple vs Output Current

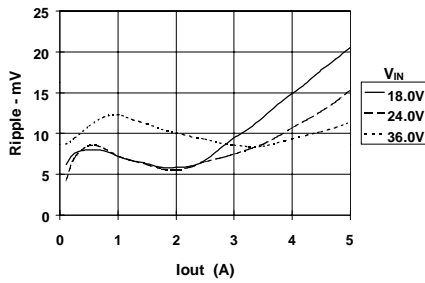

Power Dissipation vs Output Current

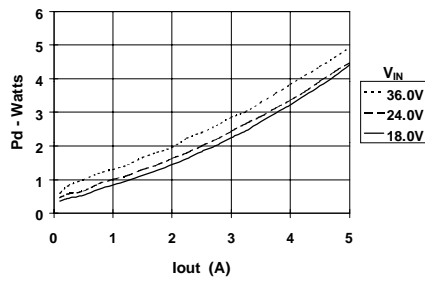

SOA Curves @ $V_{in} = +24V$ (Note B)

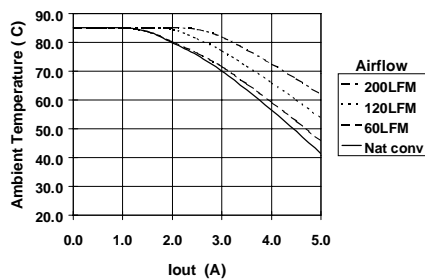

Note A: Characteristic data in the above graphs has been developed from actual products tested at 25°C. This data is considered typical for the ISR.
Note B: SOA curves represent conditions at which internal components are at or below manufacturer's maximum operating temperatures.

Adjusting the Output Voltage of the PT6880 5Amp 18-36V Excalibur™ Converter Series

The output voltage of the Power Trends PT6880 Excalibur Series ISRs may be adjusted higher or lower than the factory trimmed pre-set voltage with the addition of a single external resistor¹. Table 1 gives the respective allowable adjustment range for each model in the series as V_a (min) and V_a (max).

Adjust Up: An increase in the output voltage is obtained by adding a resistor R2, between pin 1 (V_o adjust) and pins 6, 7, & 11-14 (GND).

Adjust Down: Add a resistor (R1), between pin 1 (V_o adjust) and pins 15-17 (V_{out}).

Refer to Figure 1 and Table 2 for both the placement and value of the required resistor, either (R1) or R2 as appropriate.

Notes:

1. Use only a single 1% resistor in either the (R1) or R2 location. Place the resistor as close to the ISR as possible.
2. Never connect capacitors from V_o adjust to either GND, V_{out} , or the Remote Sense pin. Any capacitance added to the V_o adjust pin will affect the stability of the ISR.
3. If the Remote Sense feature is being used, connecting the resistor (R1) between pin 1 (V_o adjust) and pin 18 (Remote Sense) can benefit load regulation.
4. For output voltages above 10.0Vdc, the maximum output current must be limited to 4Adc.
5. Adjustments to the output voltage may place additional limits on the input voltage for the part. The revised limits must comply with the following requirements.

$$V_{in} \text{ (min)} = (V_{out} + 3)V \text{ or } 18V, \text{ whichever is higher.}$$

$$V_{in} \text{ (max)} = (10 \times V_{out})V \text{ or } 36V, \text{ whichever is less.}$$

Table 1

PT6880 ADJUSTMENT AND FORMULA PARAMETERS

Series Pt #	PT6882	PT6881	PT6883	PT6884	PT6886	PT6885
V_o (nom)	2.5V	3.3V	5.0V	9.0V	12.0V	15.0V
V_a (min)	1.8V	2.2V	3.0V	6.0V	9.0V	10.0V
V_a (max)	4.3V	4.7V	6.5V	10.2V	13.6V	17.0V
R_o (k Ω)	4.99	4.22	2.49	2.0	2.0	2.0
R_s (k Ω)	2.49	4.99	4.99	12.7	12.7	12.7

Figure 1

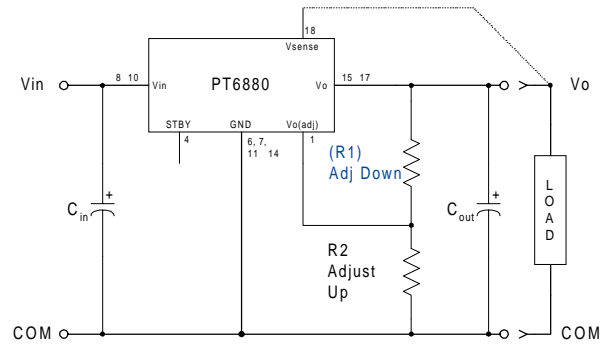

The values of (R1) [adjust down], and R2 [adjust up], can also be calculated using the following formulae.

$$(R1) = \frac{R_o (V_o - 1.25)(V_a - 1.25)}{1.25 (V_o - V_a)} - R_s \quad k\Omega$$

$$R2 = \frac{R_o (V_o - 1.25)}{V_a - V_o} - R_s \quad k\Omega$$

Where: V_o = Original output voltage
 V_a = Adjusted output voltage
 R_o = The resistance value in Table 1
 R_s = The series resistance from Table 1

PT6880 Series

Table 2

PT6880 ADJUSTMENT RESISTOR VALUES

Series Pt #	PT6882	PT6881	PT6883	Series Pt #	PT6884	PT6886	PT6885
Current	5Adc	5Adc	5Adc	Current	5Adc	4Adc	4Adc
V _o (nom)	2.5Vdc	3.3Vdc	5.0Vdc	V _o (nom)	9.0Vdc	12.0Vdc	15.0Vdc
V _a (req'd)				V _a (req'd)			
1.8	(1.4)kΩ			6.0	(6.9)kΩ		
1.9	(2.9)kΩ			6.2	(9.2)kΩ		
2.0	(5.0)kΩ			6.4	(11.9)kΩ		
2.1	(8.1)kΩ			6.6	(14.0)kΩ		
2.2	(13.3)kΩ	(1.0)kΩ		6.8	(18.6)kΩ		
2.3	(23.7)kΩ	(2.3)kΩ		7.0	(23.0)kΩ		
2.4	(54.9)kΩ	(3.9)kΩ		7.2	(28.3)kΩ		
2.5		(5.8)kΩ		7.4	(35.0)kΩ		
2.6	59.9kΩ	(8.4)kΩ		7.6	(43.5)kΩ		
2.7	28.7kΩ	(11.7)kΩ		7.8	(55.0)kΩ		
2.8	18.3kΩ	(16.5)kΩ		8.0	(71.0)kΩ		
2.9	13.1kΩ	(23.6)kΩ		8.2	(95.0)kΩ		
3.0	10.0kΩ	(35.4)kΩ	(1.6)kΩ	8.4	(135.0)kΩ		
3.1	7.9kΩ	(59.0)kΩ	(2.3)kΩ	8.6	(215.0)kΩ		
3.2	6.4kΩ	(130.0)kΩ	(3.1)kΩ	8.8	(455.0)kΩ		
3.3	5.3kΩ		(4.0)kΩ	9.0		(31.7)kΩ	
3.4	4.4kΩ	81.5kΩ	(5.1)kΩ	9.2	64.8kΩ	(36.1)kΩ	
3.5	3.8kΩ	38.3kΩ	(6.2)kΩ	9.4	26.1kΩ	(41.2)kΩ	
3.6	3.2kΩ	23.8kΩ	(7.6)kΩ	9.6	13.1kΩ	(47.1)kΩ	
3.7	2.7kΩ	16.6kΩ	(9.1)kΩ	9.8	6.7kΩ	(54.1)kΩ	
3.8	2.3kΩ	12.3kΩ	(10.9)kΩ	10.0	2.8kΩ	(62.6)kΩ	(25.8)kΩ
3.9	2.0kΩ	9.4kΩ	(13.0)kΩ	10.2	0.2kΩ	(72.8)kΩ	(28.3)kΩ
4.0	1.7kΩ	7.4kΩ	(15.6)kΩ	10.4		(85.7)kΩ	(31.1)kΩ
4.1	1.4kΩ	5.8kΩ	(18.7)kΩ	10.6		(102.0)kΩ	(34.1)kΩ
4.2	1.2kΩ	4.6kΩ	(22.6)kΩ	10.8		(124.0)kΩ	(37.3)kΩ
4.3	1.0kΩ	3.7kΩ	(27.6)kΩ	11.0		(155.0)kΩ	(40.9)kΩ
4.4		2.9kΩ	(34.2)kΩ	11.2		(201.0)kΩ	(44.9)kΩ
4.5		2.2kΩ	(43.6)kΩ	11.4		(278.0)kΩ	(49.3)kΩ
4.6		1.7kΩ	(57.6)kΩ	11.6		(432.0)kΩ	(54.3)kΩ
4.7		1.2kΩ	(80.9)kΩ	11.8		(895.0)kΩ	(59.8)kΩ
4.8			(128.0)kΩ	12.0			(66.1)kΩ
4.9			(268.0)kΩ	12.2		94.8kΩ	(73.3)kΩ
5.0				12.4		41.1kΩ	(81.6)kΩ
5.1			88.4kΩ	12.6		23.1kΩ	(91.3)kΩ
5.2			41.7kΩ	12.8		14.2kΩ	(103.0)kΩ
5.3			26.1kΩ	13.0		8.8kΩ	(117.0)kΩ
5.4			18.4kΩ	13.2		5.2kΩ	(133.0)kΩ
5.5			13.7kΩ	13.4		2.7kΩ	(154.0)kΩ
5.6			10.6kΩ	13.6		0.7kΩ	(181.0)kΩ
5.7			8.4kΩ	13.8			(217.0)kΩ
5.8			6.7kΩ	14.0			(268.0)kΩ
5.9			5.4kΩ	14.2			(343.0)kΩ
6.0			4.4kΩ	14.5			(570.0)kΩ
6.1			3.5kΩ	15.0			
6.2			2.8kΩ	15.5			42.3kΩ
6.3			2.2kΩ	16.0			14.8kΩ
6.4			1.7kΩ	16.5			5.6kΩ
6.5			1.2kΩ	17.0			1.1kΩ

R1 = (Blue) R2 = Black